

## TECHNICAL DATASHEET TURBOPUMP

# IRX 085 - ... / ...



**rovatti pompe**  
Products you can rely on

*Illustrative purposes only; the model shown here could be different that one supplied*

### STANDARD EQUIPMENT

Engine complete with manual accelerator and silencer:

Brand:	FPT – Fiat Powertrain Technologies
Model:	F32 MNSX
Normative:	TIER III A
Nr. Cylinders:	4
Displacement:	3.200 cc
Suction:	Turbocharged
Cooling system:	Liquid
Continuous power @ 1750 rpm:	47 kW – 64 HP
Continuous power @ 2000 rpm:	51 kW – 70 HP
Continuous power @ 2200 rpm:	53 kW – 72 HP
Maximum power @ 2500 rpm:	55 kW – 75 HP
Starting:	Electric starting
Incorporated fuel tank:	120 lt.

Engine protective panel model **EasyMOP**, complete with fuel level indicator, tachometer, hour meters, pressure gauge, pressostat, timer, starting key, luminous devices for detecting emergency signal; it stops engine in case of low oil pressure, engine overheating, belt breakage, water pressure fall.

Two tyres chassis painted RAL 5017 complete with incorporated fuel tank, 3 stacker legs, shaft with adjustable height, document holder and electric starting battery.

Elastic coupling between engine and pump.

Suction and delivery flanges on the pump.

Rovatti pump (see Models and Performances)

## Models and Performances

Model	Rpm	Consump. (l/h)	Pump	Nr. Impellers	Suction	Delivery	Performances			Coupling	
IRX085-10/OR	2000	11,4	S3P125K/M	1	DN125	DN100	Cap. (l/min)	2750	2500	2000	Horizontal
IRX085-10/FL			F34P125K/M				Head (mca)	61	63	65	Flanged
IRX085-20/OR	2000	11,4	S3K100H/2G	2	DN100	DN80	Cap. (l/min)	2000	1800	1600	Horizontal
IRX085-20/FL			F33K100H/2G				Head (mca)	92	96	99	Flanged
IRX085-30/OR	2000	11,4	S3K100H/3L	3	DN100	DN80	Cap. (l/min)	1400	1200	1000	Horizontal
IRX085-30/FL			F33K100H/3L				Head (mca)	123	127	130	Flanged
IRX085-35/OR	2000	11,4	S4K100-120/4F	4	DN100	DN80	Cap. (l/min)	1200	1600	1800	Horizontal
IRX085-35/FL			F34K100-120/4F				Head (mca)	128	114	104	Flanged
IRX085-40/OR	2000	11,4	S3K80-90/6E	6	DN80	DN65	Cap. (l/min)	1400	1100	600	Horizontal
IRX085-40/FL			F33K80-90/6E				Head (mca)	112	140	163	Flanged
IRX085-50/OR	2000	11,4	S3K80-90/7E	7	DN80	DN65	Cap. (l/min)	1100	1200	1300	Horizontal
IRX085-50/FL			F33K80-90/7E				Head (mca)	163	154	143	Flanged

## Weight and overall dimensions

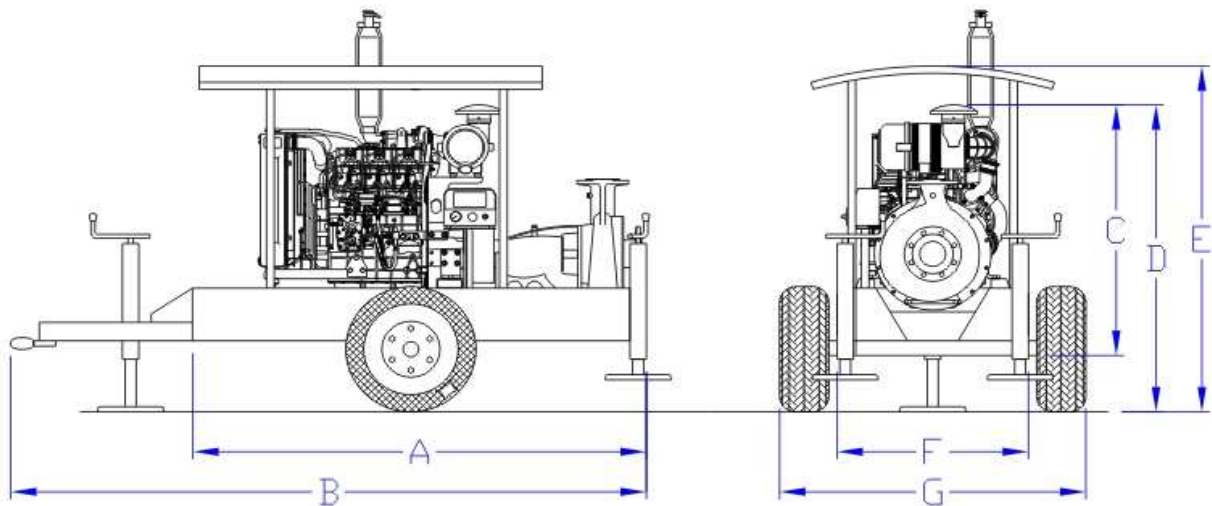

Fuel tank	A (mm)	B (mm)	C (mm)	D (mm)	E (mm)	F (mm)	G (mm)	Wheels	Dry weight (kg)
<b>120 lt</b>	2392	3270	1030	1310	1740	800	1230	185/65 R14 5F	
<b>280 lt</b>	2400	3750	1080	1380	1810	1000	1470	205/60.15 5F	
<b>420 lt</b>	2400	3750	1080	1410	1840	1200	1740	10.0/80-12 pr6 5F	
<b>500 lt</b>	2800	4150	1080	1410	1840	1200	1740	10.0/80-12 pr6 5F	